

SECTION 'XX'
(SHAFT END)

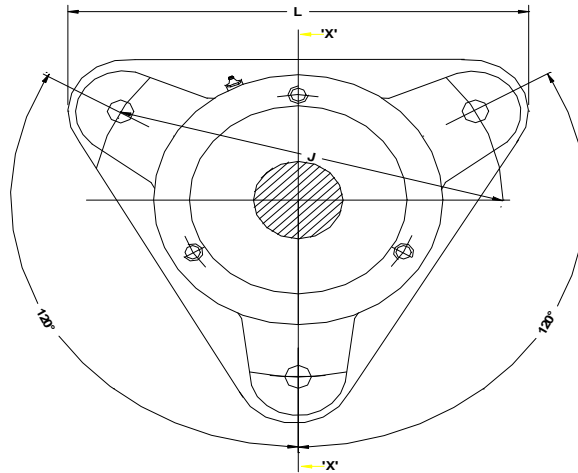

ELEVATION

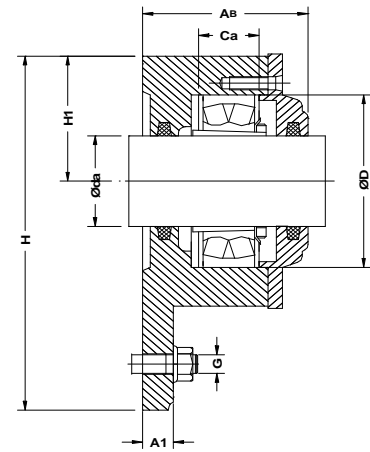

SECTION 'XX'
(THROUGH SHAFT)

**Masta Brand Triangular Flanged Bearing Housing
for bearing with adapter sleeve.**

Plummer Block Designation	Shaft dia	DIMENSIONS IN MM													Appropriate Bearing No. Sleeve	Felt strip
		AA	AB	A1	Ba	Bb	D1	H	H1	J	L	G	Ca	D		
722505	20	51.5	56.5	10	15	12.5	75	100	38	96	110	10	20	52	1205 EK + H 205 2205 EK + H 305 22205 EK + H 305	FS110
722506	25	57	59.5	12	16	15	86	117	44	116	130	10	22	62	1206 EK + H 206 2206 EK + H 306 22206 EK+ H 306	FS190
722507	30	59.5	63.5	12	16	14.5	97	130	48.5	130	145	12	25	72	1207 EK + H 207 2207 EK + H 307 22207 EK+ H 307	FS190
722508	35	64	65.5	12	17	18	108	143	54	140	160	12	25	80	1208 EK + H 208 2208 EK + H 308 22208 EK+ H 308	FS 190
722509	40	64.5	69.5	12	19	16.5	113	160	60	160	180	12	25	85	1209 EK + H 209 2209 EK + H 309 22209 EK+ H 309	FS190
722510	45	68.5	73	15	22	17.5	118	160	60	180	180	12	25	90	1210 EK + H 210 2210 EK + H 310 22210 EK+ H 310	FS 190
722511	50	75.5	81.5	15	24	19.5	128	172	65	192	192	12	27	100	1211 EK + H 211 2211 EK + H 311 22211 EK+ H 311	FS260
722512	55	77	82	15	23	19	142	189	72	210	210	12	30	110	1212 EK + H 212 2212 EK + H 312 22212 EK+ H 312	FS 260
722513	60	80	86	15	22	20	152	203	78	225	225	12	30	120	1213 EK + H 213 2213 EK + H 313 22213 EK+ H 313	FS 260